

CT 2 ENDURO

Displacement: 171cc
 Bore and Stroke: 66 x 50mm
 Number of Cylinders: 1
 Use: Street and Trail
 Cylinder Head Volume: 24.6cc
 P/N 314-11111-00-00
 Compression Ratio: 6.8 to 1
 Carburetor Size: VM 24 SH
 P/N 314-14101-00-00
 Ignition Timing: 1.8mm BTDC
 Spark Plug Heat Range: NGK B 8 ES

Special Parts:

Wide Ratio Transmission

CT 2 ENDURO

Port Diagram
Cylinder Part No. 314-11311-00-00
All Dimensions in Millimeters:
Tolerance: $\pm 0.5\text{mm}$

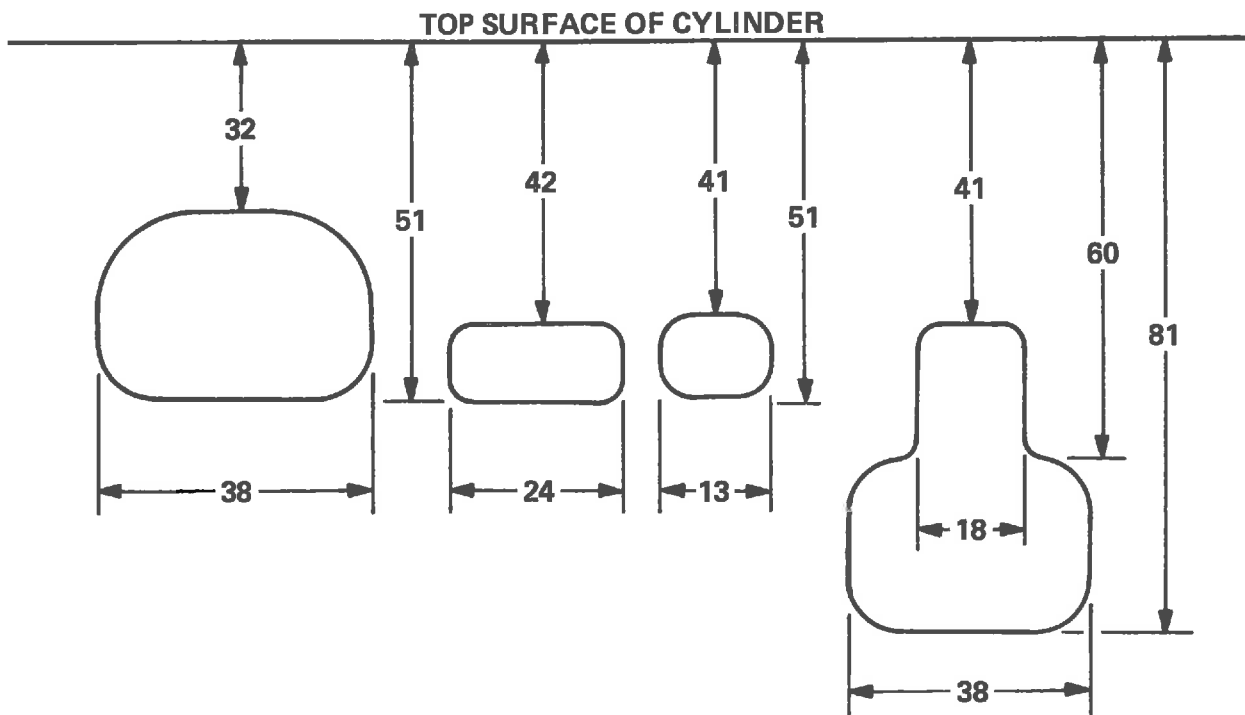

CT 2 ENDURO

Piston Diagram
Piston No. 314-11631-00-96
All Dimensions in Millimeters:
Tolerance: $\pm 0\text{mm}$

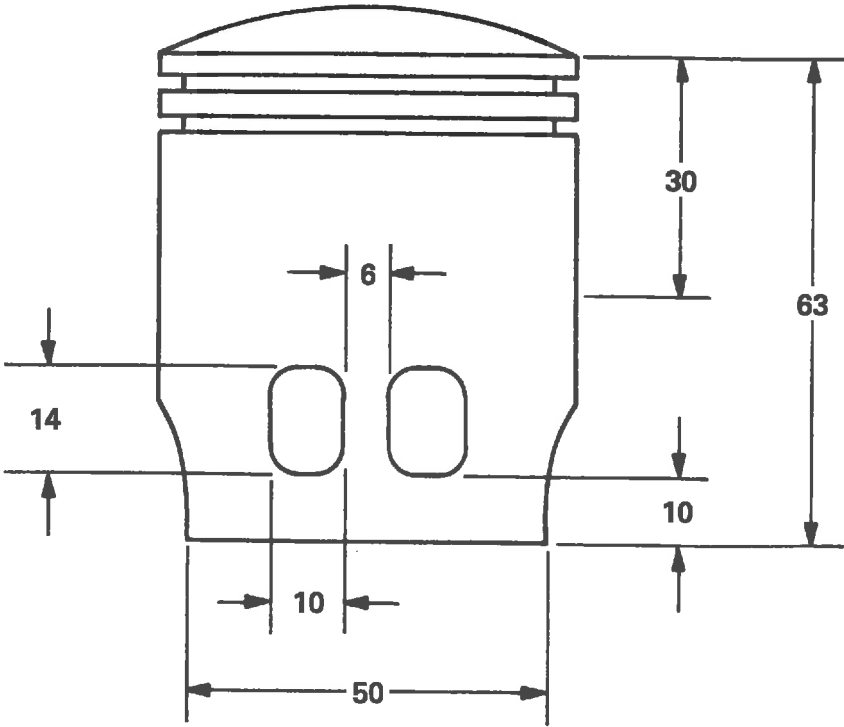

CT 2 MOTOCROSS

Displacement: 171cc
 Bore and Stroke: 66 x 50mm
 Number of Cylinders: 1
 Use: Motocross and Scrambles
 Cylinder Head Volume: Not Available
 Modified Cylinder Head
 P/N 314-11111-00-00
 Compression Ratio: 7.8 to 1
 Carburetor Size: VM 26 SC
 P/N 318-14101-00-00
 Ignition Timing: 2.0mm BTDC
 Spark Plug Heat Range: NGK B 9 ES

Special Parts:

Rod Bearing: Silver Cage
 P/N 93310-42277-00
 Close Ratio Transmission: AT 2M
 Expansion Chamber: AT 2M
 P/N 318-14610-00

CT 2 MOTOCROSS

Port Diagram
Cylinder Part No. 413-11311-00-00
Modified
All Dimensions in Millimeters:
Tolerance: $\pm 0.5\text{mm}$

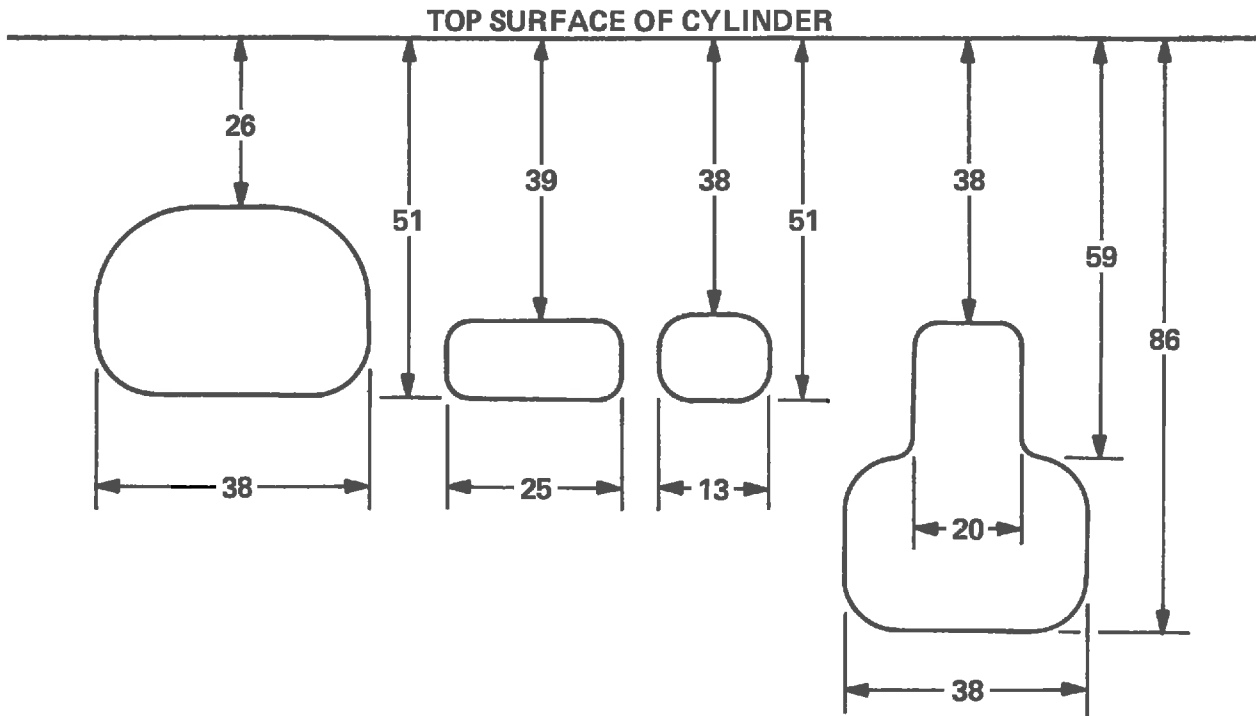

CT 2 MOTOCROSS

Piston Diagram
Piston Part No. 314-11631-00-96
All Dimensions in Millimeters:
Tolerance: $\pm 0\text{mm}$

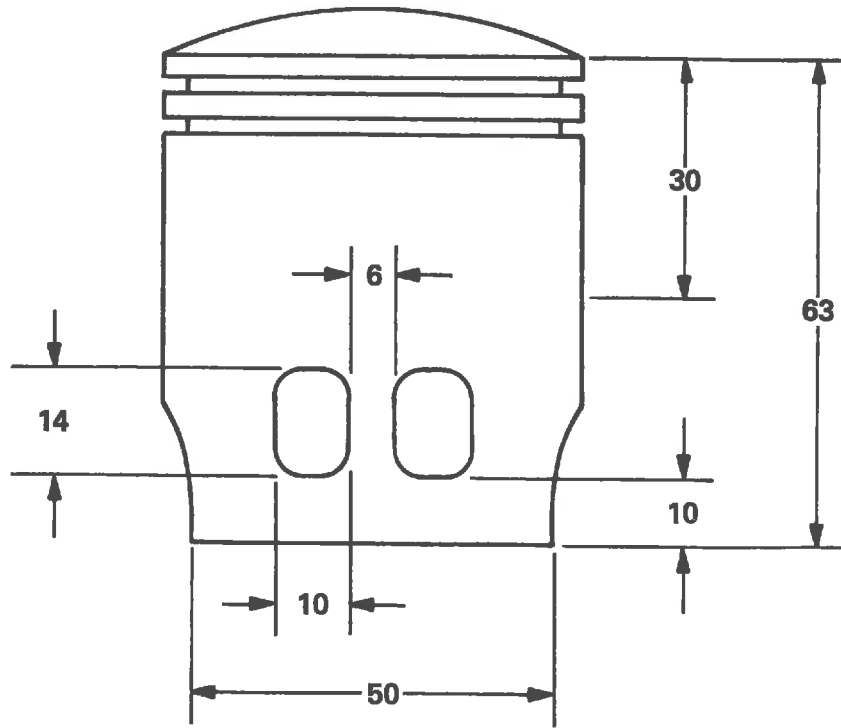

1972

CT 2 MOTOCROSS

Expansion Chamber

P/N 318-14610-00-00

Material Thickness 1mm

All Dimensions in Millimeters:

Tolerance: $\pm 1.0\text{mm}$

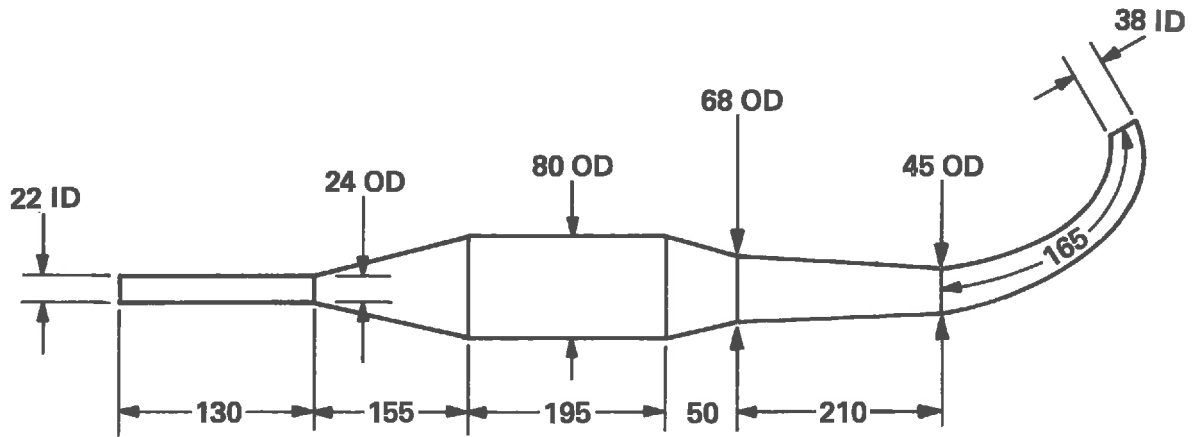

CT 2 MOTOCROSS SPECIAL

Displacement: 171cc
 Bore and Stroke: 66 x 50mm
 Number of Cylinders: 1
 Use: Short Track and TT
 Cylinder Head Volume: Not Available
 P/N 314-11111-00-00
 Compression Ratio: 7.6 to 1
 Carburetor Size:
 P/N 313-14101-60-00 VM 30 SC
 P/N 322-14101-60-00 VM 34 SC
 Ignition Timing: 2.0mm BTDC
 Spark Plug Heat Range: NGK B 9 EN

Special Parts:

Rod: Slotted — 2mm wide and 10mm long
 Rod Bearing: Silver Cage, TD and TR-3
 P/N 93310-42255-00
 Close Ratio Transmission: AT 2 MX
 Expansion Chamber: AT 2 MX
 P/N 318-14610-00-00

1972

CT 2 MOTOCROSS SPECIAL

Port Diagram

Cylinder Part No. 314-11311-00-00

Modified

All Dimensions in Millimeters:

Tolerance: $\pm 0.5\text{mm}$

NOTE

When widening rear transfer port, widen toward the rear boost port.

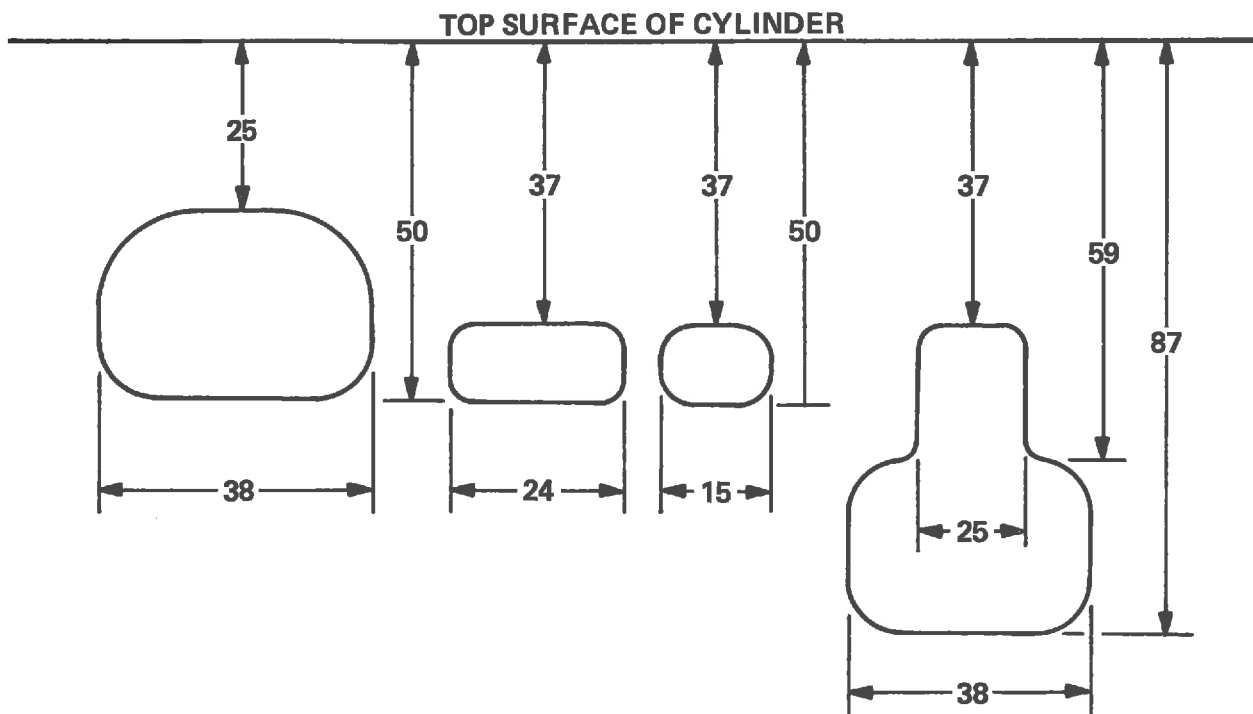

CT 2 MOTOCROSS SPECIAL

Piston Diagram
Part No. 314-11631-00-96
All Dimensions in Millimeters:
Tolerance: $\pm 0\text{mm}$

CAUTION

After cutting off a portion of the piston skirt, be sure to check for cracks along edge of skirt and around intake ports after each race.

If there is evidence of cracks or extreme wear, replace piston.

NOTE

When modifying piston, be sure only to modify the intake side. This will change port timing.

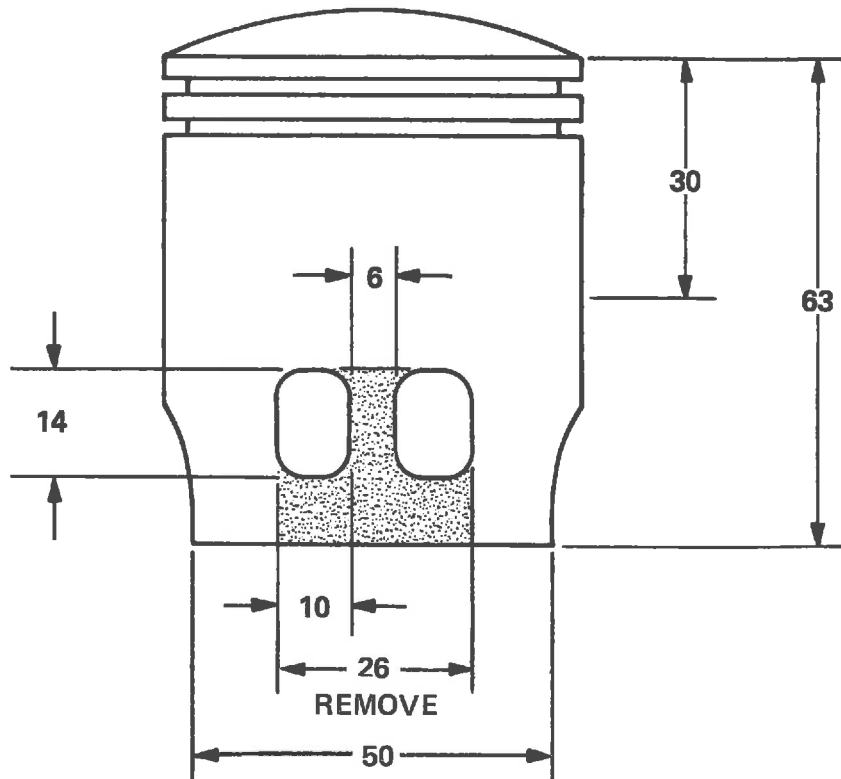

1972

CT 2 MOTOCROSS SPECIAL

Expansion Chamber

Part No. 318-14610-00-00

Material Thickness 1mm

All Dimensions in Millimeters:

Tolerance: $\pm 0.5\text{mm}$

